



PRODUCT HIGHLIGHTS

- Compatible with all RTP3000 TAS systems (SIS, DCS, PLC)
- Cost Effective
- HART Compatible
- Voltage Input Options – 0V to 10V or $\pm 10V$
- Current Input Options – 4 to 20mA, 0 to 20 mA, or $\pm 20mA$
- 1 msec SOE resolution

Product Overview

The 32-Channel Analog Input card provides a low cost option for use in general purpose PLC or DCS systems as well as for functionality not directly related to safety instrumented functions in SIL rated systems. The analog input card can be installed into any 3000TAS family chassis and provide measurements signals such as pressure, temperature, flow rate, position, etc.

The 3214 Analog Input card can be used with HART enabled devices to improve process efficiency, reduce maintenance requirements and enhance overall productivity. This can be accomplished through the use of Cornerstone™, FieldVue™, RTP's Multiplexer software, or other well known software packages and RTP's HART Communications Card (3018).

32 single ended analog input channels are available and can record SOE data with 1 millisecond timestamp resolution. The card is capable of processing input signals of 0-10 volts, +/- 10 volts, 0-20 mA, +/- 20 mA and 4-20 mA. When used with current inputs, the termination module includes a 250 Ω precision resistor per channel to convert the current to voltage.

In addition to the 32 input channels, two calibration channels are provided to monitor the onboard precision voltage source at the high end and low end. These voltages provide the user with a known precise reference to verify the A/D calibration.

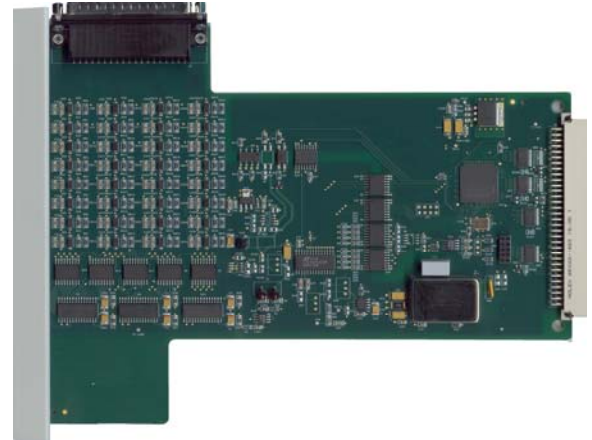

3214 32-Channel Analog Input Card

Out of tolerance readings on either the high or low calibration channels will set the corresponding error bit in the integer error detection word of the analog input card.

Each card includes a five foot termination cable which can be connected to the RTP field termination module or existing terminal blocks. When using existing terminal blocks, the termination cable can be ordered with a connector on one end to mate to the card and stripped wires on the other end to mate to the existing termination assembly.

RTP is the Best Technology for Your Investment,

Here's why:

The 3000 TAS is a multi-processor architecture that delivers exceptional Performance and Comprehensive Diagnostics. The results speak for themselves: A reaction time of 12 msec, true 1 msec SOE (Analog and Digital), an MBTF of greater than 50000 years an MTTFS of greater than 60000 years, and a PFDavg of 5×10^{-5} . **Compare these numbers to any other system.**

Built-in proof test diagnostics means it will never be necessary to shut down at the proof test interval. Unlimited online downloads of logic and configuration changes do not require a periodic shut down like other systems. **Compare this functionality to any other system.**

NetSuite Software: One-time price includes unlimited use of Logic Development, Alarm Manager, Data Archive and Historian and HMI without hardware or software keys. **Compare this functionality and price to all other systems.**

Finally, a Safety Instrumented System (SIS) should always take the process it protects to a safe state when it is required to do so, and it should never interfere with the operation of the process at the time. **The 3000 TAS does this better than any other system.**

Diagnostics detect the presence of the field termination cable. If the cable connection is insecure or removed, it will result in the card being placed offline and an error message being displayed in the device status window. The corresponding error bit is set in the integer error detection word.

Should a card need replaced, it can be done while the system is running. Simply disable the card from within NetArrays, remove the cable attached to the card, replace the card, attach the cable to the card, and enable the card within NetArrays. A front panel LED indicates if the card is online or offline.

Specifications

Number of Channels	32
Input Signals	Voltage: 0-10 VDC, ± 10 VDC Current: 4-20 mA, 0-20 mA, ± 20 mA
Full Scale Value	Voltage: 10V Current: 20mA
Input Signal Guard Band	1%
Input Impedance	Voltage: >2 Mega Ohms Current: 250 Ohms
Input Bias Current	4.55 μ A maximum
Max Input Source Impedance	Voltage: 1000 Ω maximum including cables
Analog input error (maximum error at 25 °C)	Voltage: $\pm 0.055\%$ full scale value Current: $\pm 0.075\%$ full scale value
Analog input error (temperature coefficient)	Voltage: ± 0.0020 full scale value/ $^{\circ}$ C Current $\pm 0.004\%$ full scale value/ $^{\circ}$ C
Maximum error over full temperature range	Voltage: $\pm 0.115\%$ full scale value Current: $\pm 0.195\%$ full scale value
Digital resolution	16 bits
Type of input	Single ended
Scan Rate	1000 sample sets per second
Input filter characteristics - order	First order
Input filter characteristics – transition frequency	-3dB @ 59.9 KHz
Type of protection	15 Volt TVS per channel, Digital isolators (magnetic)
Isolation	500V Channel to RTP BUS
Common points between channels	All channels share a single common
Crosstalk between channels at d.c., a.c. 50 Hz and a.c. 60 Hz	-84 dB
Non-linearty	$\pm 0.028\%$ of full scale value
Repeatability at fixed temperature after 10 second stabilization time	$\pm 0.028\%$ of full scale value
Power Dissipation	3.8 Watts or 13 BTU/hr
Backplane Power	5VDC @ 400 mA supplied by the RTP backplane 24VDC @ 75 mA

Environmental Specification

Operating Temperature Range	-20°C to +60°C
Storage Temperature Range	-25°C to +85°C
Relative Humidity Range	10% to 95%, non-condensing

Termination Module

3099/21-102	Single Termination Module - 32 channel voltage input
3099/21-002	Triple Termination Module - 32 channel voltage input
3099/21-107	Single Termination Module - 32 channel current input w/ removable field wiring connection
3099/21-007	Triple Termination Module - 32 channel current input w/ removable field wiring connection
3099/55-100	Single Termination Module - 32 channel voltage input - rotatable mounting
3099/55-101	Single Termination Module - 32 channel current input - rotatable mounting

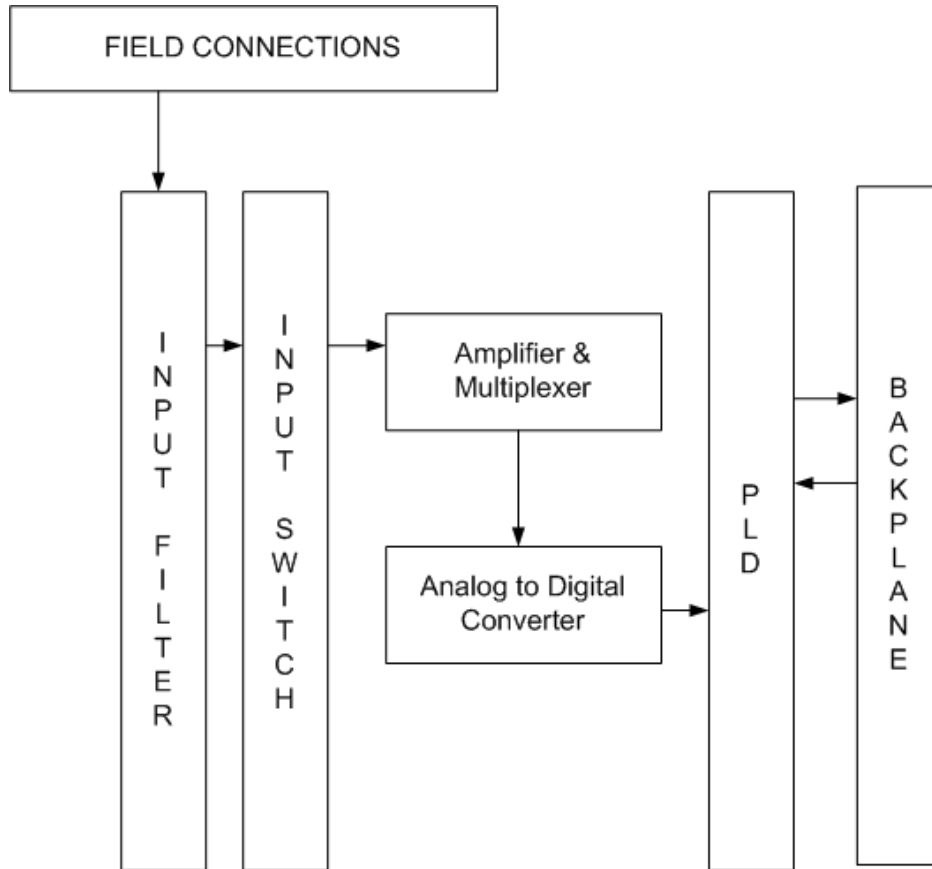

Trademark acknowledgments: RTP is a registered trademark of RTP Corp. All other product or service names mentioned herein are trademarks of their respective owners. Specifications and information are subject to change without notice. Contact RTP Corp office for the latest specifications.

All information, data graphics and statements in this document are proprietary intellectual property of RTP Corp. unless otherwise indicated and are to be considered RTP Corp. confidential. This intellectual property is made available solely for the direct use of the potential or licensed RTP corp. customers in their application of RTP Corp. produces, and any other use or distribution is expressly prohibited. If you have received this publication in error, immediately delete, discard or return to RTP Corp.