

# SIMON™, the BWR-stability monitor

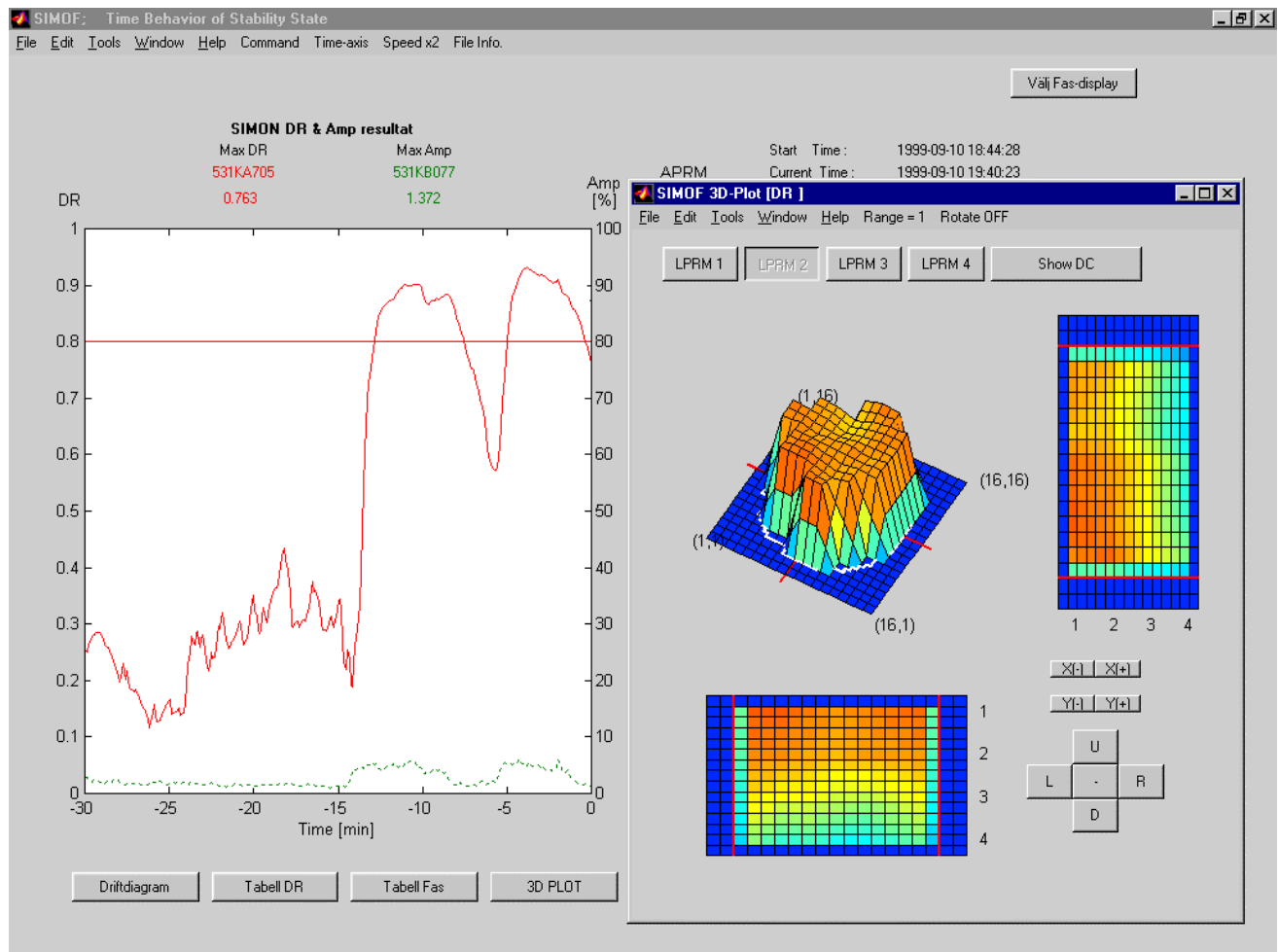

BWR instabilities can arise at high power and low core flow conditions e.g. during start-up. Power oscillations may occur in global, regional or local mode. Recently observed events in Sweden and abroad have caused scrams due to lacking on-line information.

SIMON™ monitors the core's stability margins on-line and traces the conditions continuously via the DR (Decay Ratio). Sophisticated space dependent out of phase oscillations can also be monitored by SIMON™.

## Early warning by SIMON™ when stability margins are reduced

SIMON™'s short response time gives the operator a chance to observe and counter act declining stability margins to avoid reactor power oscillations with high amplitude.

SIMON™ monitors neutron signals (both APRM's and LPRM's). With all independent neutron signals connected to SIMON™ it is possible to overview the core in one glance.

Among others, the signal with the actually largest DR is indicated separately. Phase difference between a number of LPRM signals from different parts of the core are monitored and the highest value is also displayed separately by SIMON™. The last measure is to monitor the regional stability.

The calculated stability parameters are stored on hard disc to be available for later analysis with our excellent off-line tools. SIMON™ has also a function as a disturbance recorder. When the instability alarm threshold is reached time series data are stored for a period of time. It is also possible to use SIMON™ as a recorder with manual start of data storage. Also these data can be analyzed with the same advanced SIMOF (SIMON™ analysis package).

A spin off feature with SIMON™ is that the software indicates internal instrument tube vibration on-line. It is well known that string vibration can cause damage to the surrounding fuel boxes. This SIMON™ indication guides the inspection during outage to the corresponding fuel boxes.

The secret with our fast, robust and accurate SIMON™ is the analysis technique with advanced recursive identification, an optimized lattice filter algorithm and years of on-site experience. The installed SIMON™ systems have demonstrated their ability to follow difficult transients (e.g. pump trips and rod pattern changes) accurately and robustly.

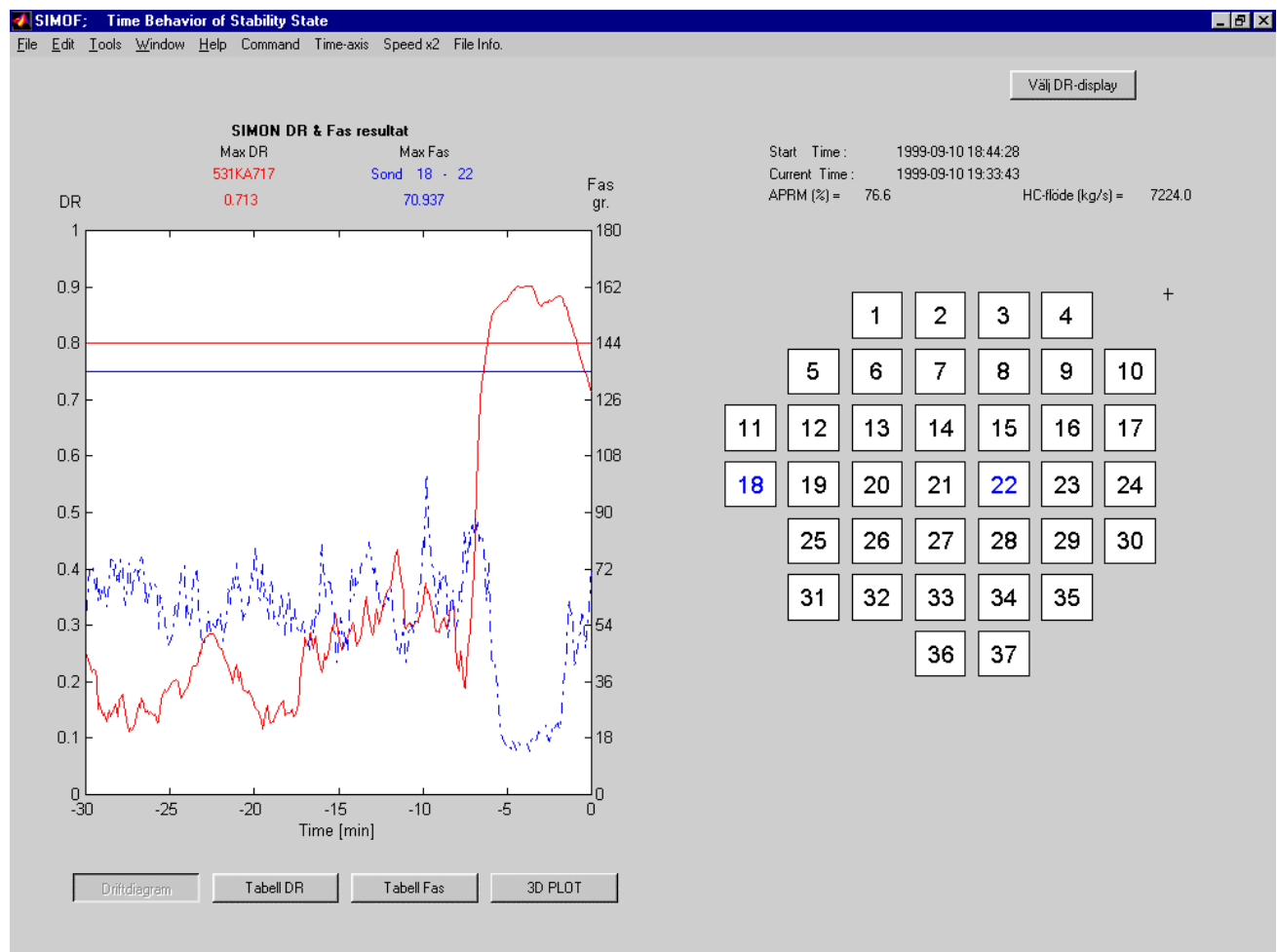

## **SIMON™ installations**

SIMON™ - the BWR-stability monitor - has been developed by GSE Power Systems AB in Sweden. The monitor is installed and in operation at:

Oskarshamn 2, since 1990, in Sweden  
Barsebaeck 1 and 2, since 1991, in Sweden  
Kernkraftwerk Muehleberg, since 1993, in Switzerland  
Kashiwazaki 4, since 1994, in Japan  
Oskarshamn 3, since 1999, in Sweden

### **SIMON™ in Oskarshamn 3**

The monitor is split into three different computer systems with network connections, see Figure 1. These are named RTP - the sampling unit - which feeds the SIMON™ computer continuously with measurement data, SIMON™ where the monitor calculations are performed and finally SIMOF where display of the results takes place.

In total 180 analogue signals are sampled by the system. These are 148 LPRM (all LPRM's available in the core), 4 APRM, 4 reactor pressure, 8 fuel assembly flow, total core flow, 8 internal pump speed, 2 MPC pressure head, 4 steam valve position and valve position bypass.

All sampled signals are transferred to the SIMON™ computer where the stability evaluation is performed. DR is calculated for all neutron signals and phase differences between 2 x 9 LPRM's from different parts of the core are monitored. These measures cover surveillance of global, local and regional stability. The highest calculated DR-value among all and the highest APRM amplitude are transferred to the control room for presentation. Alarms when maximum DR > 0.8 and maximum phase difference > 135 degrees are also transferred to the control room together with watchdog information.

## **SIMOF, the advanced software for on-line and off-line use**

The result of the calculations are also transferred to the SIMOF computer with the following on-line and off-line presentation:

- The SIMOF computer is normally running in monitor mode with on-line display of the trend curves for DR, amplitude and phase difference. Graphics with the operational diagram and the core with belonging detector strings are also available in the presentation. Furthermore, there is a table mode display where the stability parameters are presented for all neutron signals.
- Playback and trend evaluation of historical data stored on hard disk by the SIMON™ computer. These results are presented as a function of time, as bar graphs or with the same type of display as in on-line mode.

There is also a possibility to analyze the collected time series data stored by SIMON™. These calculations includes AR (Auto Regressive) modelling, calculation of impulse response and auto power spectrum density. Plotting of the time series data is of course also possible.

For further information please contact:

GSE Power Systems AB  
P.O. Box 62  
SE-611 22 Nykoping  
Sweden  
Telephone: +46 (0)155 787 00  
Telefax: +46 (0)155 28 97 77  
E-mail: power@gses.se

Information to the control room

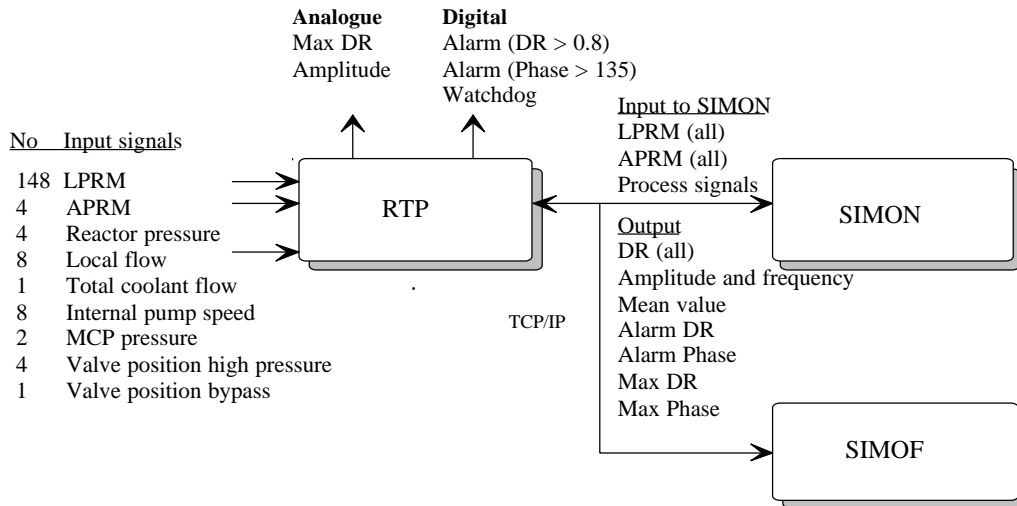

Figure 1 SIMON in Oskarshamn 3. The relation between RTP, SIMON and SIMOF softwares.

