



SIL-3 32-Channel Analog Input Card

3148/3149/3150/3151/3152

PRODUCT HIGHLIGHTS

- SIL-3 Approved
- 4 to 20 mA Input with HART option
- 0 to 20 mA Input
- ± 10 V Input
- 1 msec SOE resolution
- Single, Dual, or Triple Redundancy

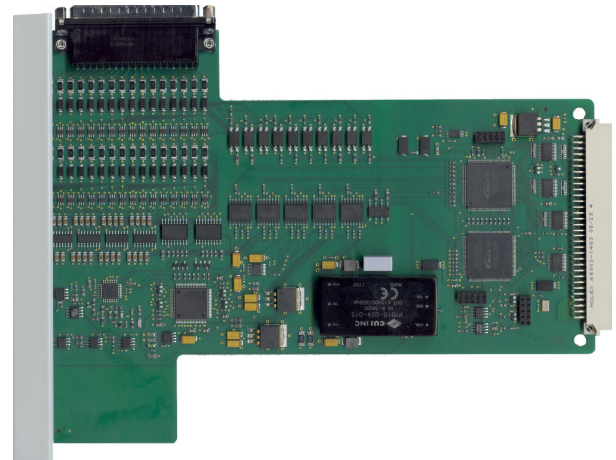

3148 32-Channel HART Enabled Analog Input Card

Product Overview

The 32-Channel Analog Input card provides high accuracy, high-level analog measurements. It can be installed into any 3000 TAS N+ family chassis and provide measurement signals such as pressure, temperature, flow rate, position, etc. A guard band above and below the full-scale signal range allows signals exceeding the specified input signal range to be detected by software. The change of any input channel state above or below a user defined threshold initiates the logging of a time stamped sequence-of-events (SOE) record with 1 msec resolution.

The 32-channel analog input card can be used with HART enabled devices to improve process efficiency, reduce maintenance requirements and enhance overall productivity. It implements all aspects of the protocol and data exchange, including message translating and formatting, message checking, and responding to HART devices with proper acknowledgments, and error or success codes.

Used in conjunction with Cornerstone™ or FieldVue™ software, the RTP Software Multiplexer translates the Hart Protocol to RTP's proprietary Protocol in order to communicate to and from the Hart enabled device. A HART modem on the card allows communication to one HART enabled device at a time. Because the data is transferred using RTP's proprietary Protocol, the communications are compliant to IEC 61508 and EN 61131-2:2007 standards.

When used in a single configuration, the 3148 and 3150 cards include 250 Ω precision resistors for each channel to convert the current to voltage. This allows the user the option of using an RTP termination module or to connect to existing terminal blocks. If connecting to existing terminal blocks, you can use a flying lead cable provided by RTP or fabricate your own termination cable.

RTP is the Best Technology for Your Investment,

Here's why:

This product is compatible with the 3000 TAS and N+ systems. It is a multi-processor architecture that delivers exceptional Performance and Comprehensive Diagnostics. The results speak for themselves: A reaction time of 7 msec, true 1 msec SOE (Analog and Digital), an MBTF of greater than 50000 years an MTTFS of greater than 60000 years, and a PFDavg of 5×10^{-5} .

Compare these numbers to any other system.

Built-in proof test diagnostics means it will never be necessary to shut down at the proof test interval. Unlimited online downloads of logic and configuration changes do not require a periodic shut down like other systems. ***Compare this functionality to any other system.*** NetSuite Software: One-time price includes unlimited use of Logic Development, Alarm Manager, Data Archive and Historian and HMI without hardware or software keys. ***Compare this functionality and price to all other systems.***

Finally, a Safety Instrumented System (SIS) should always take the process it protects to a safe state when it is required to do so, and it should never interfere with the operation of the process at the time. ***The 3000 TAS does this better than any other system.***

The 3149 and 3151 cards are used for redundant configurations and move the 250Ω precision resistors to the termination module. The 3152 card is used for voltage inputs.

Replacing the card can be done while the system is running. Simply disable the card from within NetArrays, remove the cable attached to the card, replace the card, attach the cable to the card, and enable the card within NetArrays. A front panel LED indicates if the card is online or offline.

Specifications

Number of Channels	32
Input Signals	Voltage: 0-10VDC, ±10VDC Current: 0-20 mA, 4-20 mA
Full Scale Value	Voltage: 10 VDC Current: 20 mA
Input Signal Guard Band	1%
Input Impedance	> 2 Mega Ohm
Input Bias Current	4.55 µA maximum
Analog input error (maximum error at 25 °C)	Voltage: ±0.025% of full scale value (±2.5 mV) Current: ±0.035% full scale value (±7µA)
Analog input error (maximum error at 25 °C) during active HART communications	+/-1.90% full scale value (±380µA) +/-0.515% full scale value (±103µA) w/ Channel Property Filter = 20, Threshold = 500 +/-0.195% full scale value (±39µA) w/ Channel Property Filter = 50, Threshold = 500
Analog input error (temperature coefficient)	Voltage: ±0.002% of full scale value/°C (±0.2mV/°C) Current: ±0.003% full scale value/ °C (±0.6 µA/°C)
Maximum error over temperature range (0 to 55 °C)	Voltage: ±0.085% of full scale value (±8.5mV) Current: ±0.125% full scale value (±25 µA)
Maximum error over full temperature range during active HART communications	±2.015% full scale value (±403µA) ±0.635% full scale value (±127µA) w/ Channel Property Filter = 20, Threshold = 500 ±0.315% full scale value (±63µA) w/ Channel Property Filter = 50, Threshold = 500
Digital resolution	16 bits
Type of input	Single ended
Scan Rate	1000 sample sets per second
Input filter characteristics - order	First order
Input filter characteristics – transition frequency	-3dB @ 5.5 KHz
Type of protection	15 Volt TVS per channel, Digital isolators (magnetic)
Isolation	500V Channel to RTP BUS
Common points between channels	All channels share a single common
Crosstalk between channels at d.c., a.c. 50 Hz and a.c. 60 Hz	-84 dB
Non-linearity	Voltage: ±0.025 % of full scale value (±2.5mV) Current: ±0.035 % of full scale value (±7µA)
Backplane Power	5VDC @ 400 mA 24VDC @ 125 mA

*The Analog Input cards with HART capabilities are only available with the N+ Series Systems

Environmental Specification

Operating Temperature Range	-20°C to +60°C
Storage Temperature Range	-25°C to +85°C
Relative Humidity Range	10% to 95%, non-condensing

Termination Module

3299-07S/D/T*	32 Channel Analog Input Termination Module - Voltage
3299-08S/D/T*	32 Channel Analog Input Termination Module - Current

*Represents (S)ingle, (D)ual, or (T)riple card redundancy

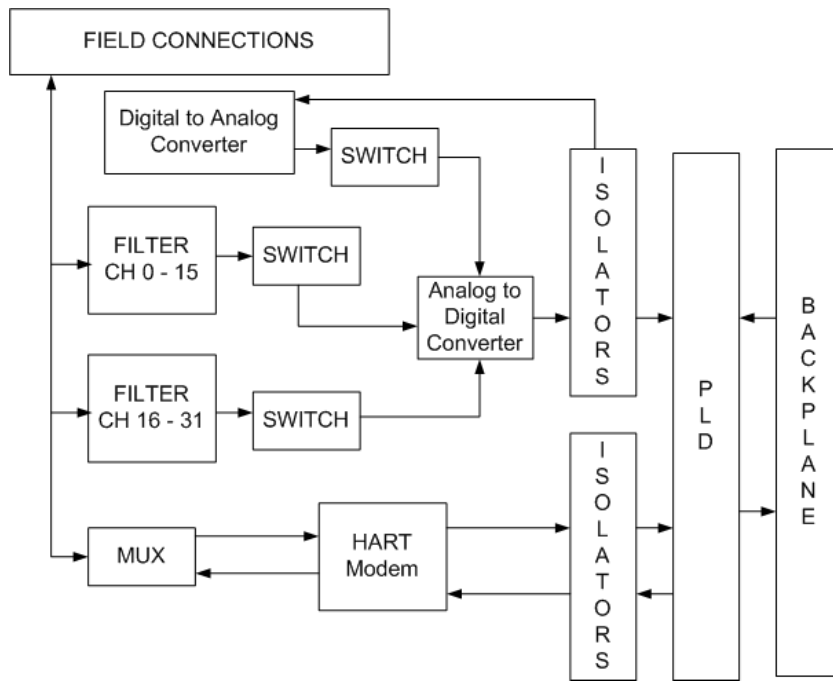

Trademark acknowledgments: RTP is a registered trademark of RTP Corp. All other product or service names mentioned herein are trademarks of their respective owners. Specifications and information are subject to change without notice. Contact RTP Corp office for the latest specifications.

All information, data graphics and statements in this document are proprietary intellectual property of RTP Corp. unless otherwise indicated and are to be considered RTP Corp. confidential. This intellectual property is made available solely for the direct use of the potential or licensed RTP corp. customers in their application of RTP Corp. produces, and any other use or distribution is expressly prohibited. If you have received this publication in error, immediately delete, discard or return to RTP Corp.